



INSTALLATION, OPERATION AND MAINTENANCE MANUAL

Mayfran CleanSweep-RM



Mayfran International, Incorporated

**P.O. Box 43038
6650 Beta Drive
Cleveland, Ohio 44143
www.mayfran.com
(440) 461-4100 tel.
(440) 461-5565 fax**

TABLE OF CONTENTS

Table of Contents	ii
Conveyor / System Information.....	1
Warranty Statement	2
Safety Information.....	3
Safety Information, Continued	4
Parts Ordering Instructions.....	5
Parts List for Conveyor.....	6
Conveyor Terminology.....	7
Operation.....	8
Installation / Start-Up.....	8
Unloading	8
Reporting Discrepancies or Damage Items	8
Lifting Guidelines for Conveyors	8
Storage of Equipment Awaiting Installation.....	9
Installation Drawings.....	9
Electrical Installation.....	9
System Installation	9
Motor Rotation Verification	9
Belt Take-Up Adjustment.....	9
Conveyor	10
Removal of Major Components.....	13
Conveyor	13
Belt Assembly Removal.....	13
Drive Assembly Removal	13
Head Shaft Assembly Removal.....	13
Major Component Replacement.....	14
Conveyor	14
Direction of Belt Travel	14
Belt Assembly Replacement	14
Procedure for Assembling Conveyor Belting (refer to the following figures)	14
Head Shaft Assembly Replacement	17
Maintenance	18
Preventive Maintenance	18
Troubleshooting	19
Overview	19
Jam Clearing Sequence.....	20
Conveyor Motion Faults	20
Overload Faults	21
Coolant Overflow Issues	21

CONVEYOR / SYSTEM INFORMATION

MACHINE INFO

Customer:	_____		
Machine Type:	_____		
Mfg. Year:	_____	Serial No:	_____
Voltage/Phase	_____	Cycle:	_____
Inspected by:	_____		

YOUR WARRANTY PERIOD

Mayfran's Warranty is given on the following page.
Your Warranty period: Date shipped _____ through _____

CUSTOMER SERVICE / PARTS ORDERS

If you have any questions or need to order parts, please contact Mayfran International at:
(440) 461-4100 Fax: (440) 461-5565 8:00 a.m. to 5:00 p.m. (EST)

THIS GUIDE IS COPYRIGHTED

All rights are reserved. This manual may not, in whole or in part, be copied, photocopied, reproduced or reduced to any form of electronic medium or machine readable form without prior consent, in writing from:

Mayfran International, Incorporated
P. O. Box 43038
Cleveland, OH 44143

Information in this manual is subject to change and is furnished to supplement, not modify the terms and conditions of Mayfran's order acknowledgment and/or signed contract with the customer.

WARRANTY STATEMENT

- (a) Material and Workmanship. Mayfran International Inc. (“Mayfran”) warrants that the equipment to be provided by it shall be of the design and construction described in its Proposal and shall be free of defects in workmanship or materials. Should any failure to conform to this warranty appear within the first 2000 hours of operation, but not later than one (1) year after shipment, Mayfran will, upon prompt notification thereof and substantiation that the equipment has been installed, maintained and operated in accordance with good industry practice and with any specific recommendations, correct such nonconformity, including nonconformity to the specifications in Mayfran’s Proposal, by in-place repair or, at its option, by furnishing a replacement part F.O.B. shipping point. Labor and equipment necessary to affect in-place repairs or component replacement are to be provided by the Buyer. Mayfran will only provide instructions and supervision to support each in-place repair. The effects of misuse, abuse, neglect, lack of proper maintenance (e.g. lubrication), corrosion, operation at other than design condition, or normal wear are specifically excluded from Mayfran’s warranty.
- (b) Performance. The only performance warranties extended by Mayfran are contained on the pages entitled “Performance Warranties” in Mayfran’s Proposal, if any. Any through-put rates contained on the Performance Warranties pages are based upon continuous operation of the equipment over the period specified without regard to whether such operation will meet Buyer's needs. Mayfran disclaims all liabilities and responsibility with respect to Buyer’s needs.

Mayfran’s total responsibility under this performance warranty shall be considered fulfilled and the equipment accepted if performance tests show that the equipment meets the conditions of performance specified by the Performance Warranties, if any, or if the equipment is not tested within 180 days of initial operation. In the event the equipment fails to meet the specified conditions of performance after properly conducted and evaluated tests, Mayfran reserves the right to make such alterations as may be necessary to meet the specified conditions free of charge to Buyer.

- (c) General. Mayfran shall not be held responsible nor shall allowance be made for work done, equipment furnished or repairs or replacements made by Buyer or by others unless prior written approval is given to Buyer by Mayfran.

With respect to accessory equipment and other vendor furnished apparatus included in its Proposal, Mayfran shall be responsible for the proper selection and specification requirements to the suppliers. Warranties for such items are limited to those extended to Mayfran by the manufacturers.

THE FOREGOING WARRANTIES ARE EXCLUSIVE AND IN LIEU OF ALL OTHER WARRANTIES, EXCEPT THAT OF TITLE, WHETHER WRITTEN, ORAL OR IMPLIED, IN FACT OR IN LAW (INCLUDING ANY WARRANTY OF MERCHANTABILITY OR FITNESS FOR A PARTICULAR PURPOSE). Correction of nonconformities whether patent or latent, in the manner and within the period of time provided above, shall constitute the fulfillment of all liabilities of Mayfran with respect to the equipment, whether based on contract, tort, strict liability or other legal theory.

In no event shall Mayfran or its contractors, subcontractors, vendors or suppliers, be liable in contract, tort, warranty, strict liability or other legal theory for any special, indirect, incidental or consequential damages such as, but not limited to, loss of anticipated profits or revenue, non-operation or increased expense of operation of other equipment, or costs of capital. The remedies of Buyer set forth herein are exclusive and the liability of Mayfran with respect to its contract or anything done in connection therewith whether in contract, tort, warranty, strict liability or other legal theory shall not exceed the purchase price of the equipment upon which liability is based. Buyer (if it will not be the ultimate owner or user of the equipment) shall obtain from the owner a written agreement that the owner will be bound by the remedies provided for herein. Buyer will also obtain from the owner a written release from consequential damages to the extent provided for herein in favor of Mayfran and its contractors, subcontractors, vendors and suppliers.

SAFETY INFORMATION

THE SAFETY INFORMATION CONTAINED HEREIN MUST BE COMMUNICATED BY THE CUSTOMER, OWNER, OR END USER TO ALL PERSONNEL WHO WILL ACTUALLY OPERATE, MAINTAIN, REPAIR, OR ADJUST THIS MACHINERY, OR WHO ARE ASSIGNED TO WORK IN THE VICINITY OF THIS MACHINERY.

ADJUSTMENT, MAINTENANCE, CLEANING AND LUBRICATION SHOULD BE CARRIED OUT ONLY BY PERSONNEL TRAINED BY THE OWNER OR END USER IN THE OPERATION OF ALL ASSOCIATED CONVEYORS AND PROCESS EQUIPMENT. PERSONNEL SHOULD BE TRAINED IN OSHA COMPLIANT LOCK-OUT / TAG-OUT AND ELECTRICAL SAFETY PROCEDURES. RECORDS OF TRAINING SHOULD BE MAINTAINED BY THE OWNER OR END USER. RECORDS OF TRAINING FOR THE SAFE OPERATION OF THIS MACHINERY MUST ALSO BE MAINTAINED. NEVER SHOULD ADJUSTMENT, MAINTENANCE, CLEANING OR LUBRICATION BE PERFORMED WITHOUT FOLLOWING PROPER SAFETY PROCEDURES.

DO NOT operate any machinery without reading and understanding this manual completely.

DO NOT operate any machinery unless fully trained and qualified by the owner or end user.

DO NOT operate any machinery (or any portion of this machinery) unless all personnel are clear of any rotating or moving parts (or parts that may potentially move or rotate).

DO NOT operate any machinery unless all guards and/or emergency stops are in place and functioning as designed by Mayfran.

DO NOT perform any maintenance, repairs or adjustments on this machinery without first locking out all electrical controls.

DO NOT perform any maintenance on moving conveyor parts.

DO NOT lubricate any machinery without first locking out all electrical controls.

DO NOT clean this machinery or the areas adjacent to or below the machinery without first locking out all electrical controls.

DO NOT touch any moving conveyor parts.

DO NOT remove any covers or guards without locking out all electrical controls.

DO NOT perform any maintenance or repairs on power lines feeding this machinery without first locking out power at the source.

DO NOT remove or cover any warning labels.

DO NOT wear loose clothing or uncovered long hair that can get caught in moving parts.

DO NOT repair or replace electrical, hydraulic, or pneumatic devices without power or air off.

DO NOT remove jammed product with conveyor running. OSHA compliant lock-out / tag-out procedures must be followed prior to clearing a jam of any type.

DO NOT operate a conveyor equipped with rope pull safety switches if the rope pull switches are not functioning properly.

DO NOT cross over a conveyor, whether or not it is operating, other than on an elevated walkway that provides safe access and prevents contact with the conveyor.

DO NOT climb on the components of a conveyor.

DO NOT ride or walk on any conveyor.

DO NOT touch moving conveyor parts.

DO NOT walk under conveyor where product can fall.

DO NOT operate conveyor without a visual or audible “all clear”.

SAFETY INFORMATION, CONTINUED

- ◆ If the entire conveyor cannot be seen from the operating station, an audible and/or visual warning shall be provided to warn of conveyor actuation.
- ◆ Conveyors should be used to transport only the material for which they were specifically designed.
- ◆ No conveyor shall be used in excess of its maximum rated speed and capacity.
- ◆ Casings, guards, safety switches, and other safety devices shall not be removed, bypassed, or disengaged during conveyor operation.
- ◆ Only trained operators shall be permitted to operate conveyors.
- ◆ All necessary guards, switches and other safety devices shall be installed so that a loss of power to the conveyor shall not render the guards, switches or safety devices inoperative.
- ◆ Each conveyor shall be kept free of accumulations of material that could inhibit its safe operation.
- ◆ Emergency controls shall be installed so that they cannot be overridden from other locations.
- ◆ Guards shall be kept in place at all times unless the electrical power is off and the conveyor is locked out
- ◆ All repairs and services shall be performed only by qualified personnel. Before repairs, tests or services are begun, all power controls shall be locked out in accordance with OSHA compliant procedures.
- ◆ Do not work near a conveyor without knowing where and how to shut it off.
- ◆ After a conveyor has been repaired, tested or serviced, it shall not be operated until all guards and safety devices have been reinstalled, all maintenance equipment has been removed and a visual inspection of the conveyor and immediate area has been completed.
- ◆ Material should not be discharged onto a conveyor that is not operating. Conversely, when stopping a conveyor or conveyor system, stop discharge of material onto initial receiving conveyor first, then continue stopping conveyors in succession after each has been cleared of its load.
- ◆ When working on the conveyor, be sure to turn the electrical disconnect OFF and LOCK OUT the power to the conveyor.
- ◆ Operators should be instructed to report any impairment of guards, emergency stop, or safety switches to their supervisors.

MAYFRAN INTERNATIONAL, INCORPORATED WILL NOT BE RESPONSIBLE FOR ANY WORK PERFORMED, OR ALTERATIONS MADE TO ANY OF ITS PRODUCTS UNLESS PRIOR APPROVAL HAS BEEN GRANTED IN WRITING BY AN AUTHORIZED MAYFRAN REPRESENTATIVE. ANY OTHER WORK WILL VOID ANY AND ALL WARRANTIES AND LIABILITIES. ALL WARRANTIES AND LIABILITIES SHALL ALSO BE VOID IF PARTS MANUFACTURED BY MAYFRAN INTERNATIONAL ARE REPLACED WITH PARTS OBTAINED FROM A SOURCE OTHER THAN MAYFRAN INTERNATIONAL.

PARTS ORDERING INSTRUCTIONS

When ordering parts, please specify the following information:

1. **Serial number:** This is a seven-digit alpha numeric designation with the following form: (12M1234). The first two digits indicate the year of manufacture, and the remaining four is a Mayfran identification number for that particular conveyor. Note: This is also the Mayfran order, or job number.
2. **Part Number:** Specify the Mayfran part number as given in this manual or as found on the drawings for the particular conveyor.
3. **Quantity:** Specify how many are required.
4. **Name of Part:** Use the proper description or title, given in the owner's manual.
5. **Shipping Instructions:** Specify complete shipping instructions: Such as parcel post, truck, 2nd day air freight, or overnight air freight, along with the required ship date. When no instructions are given, shipping method will be best way, depending on nature of part and urgency of repair. Freight costs will be paid by customer.
6. **Return Address:** When ordering parts, always include your complete address with phone number. Keep in mind that parts cannot be delivered to a Post Office box.
7. **Returned Parts:** New parts returned to the factory will be subject to a restocking charge incurred, unless parts were sent by mistake from the factory. No part may be returned to the factory without prior written authorization from Mayfran (RGT #).
8. **Shortage:** If any parts are missing, other than parts marked back ordered, call the factory immediately.



P.O. BOX 43038
6650 BETA DRIVE
CLEVELAND, OHIO 44143

PHONE: (440) 461-4100
FAX: (440) 461-5565

PARTS LIST FOR CLEANSWEEP-RM CONVEYOR

INDEX NO.	PART NAME
4-7	REPLACEMENT BELTING
4-7A	Roller Block Assembly
4-7B	Roller
4-7C	Bushing
4-7D	Side Bar, Bush Hole
4-7E	Side Bar, Small D-Hole
4-7F	Side Bar, Round Hole
4-7G	Belt Pin
4-7H	Cotter Pin
4-7J	Hinge Link
4-7K	Side Wing, Right Hand
4-7L	Side Wing, Left Hand
4-7M	Outer Cleat
4-7N	Inner Cleat
4-7O	Wiper Assembly
4-7P	Brush Assembly

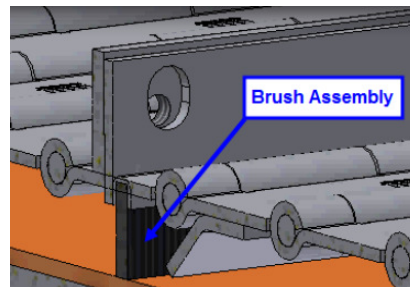
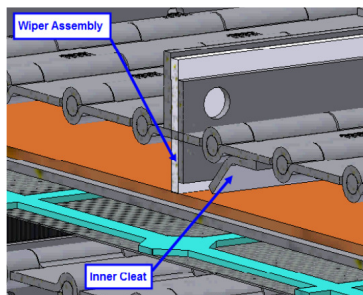
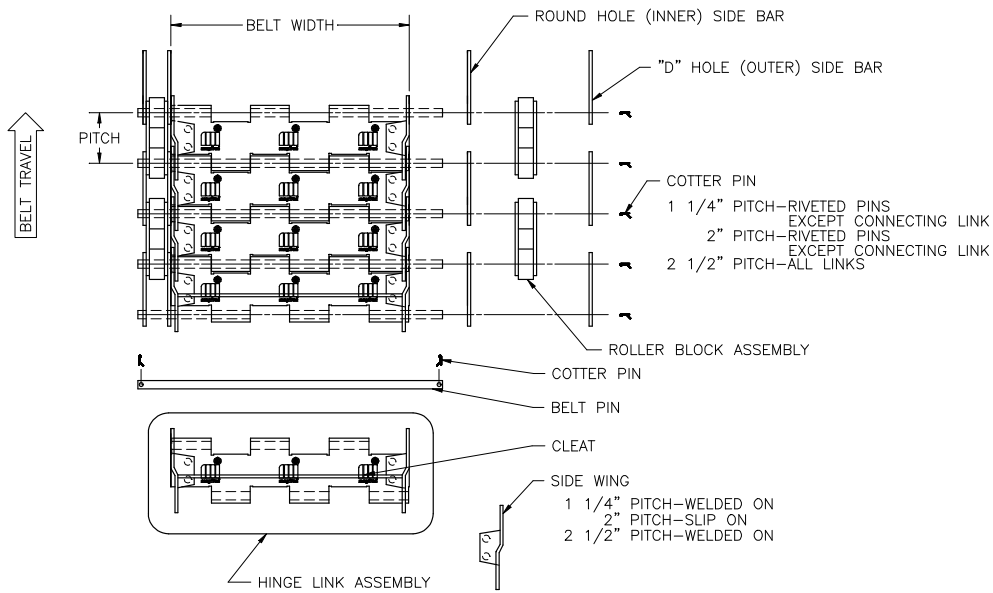

All drawings shown are typical examples of Mayfran equipment provided for the purpose of customer education only, and are subject to change.

CONVEYOR TERMINOLOGY

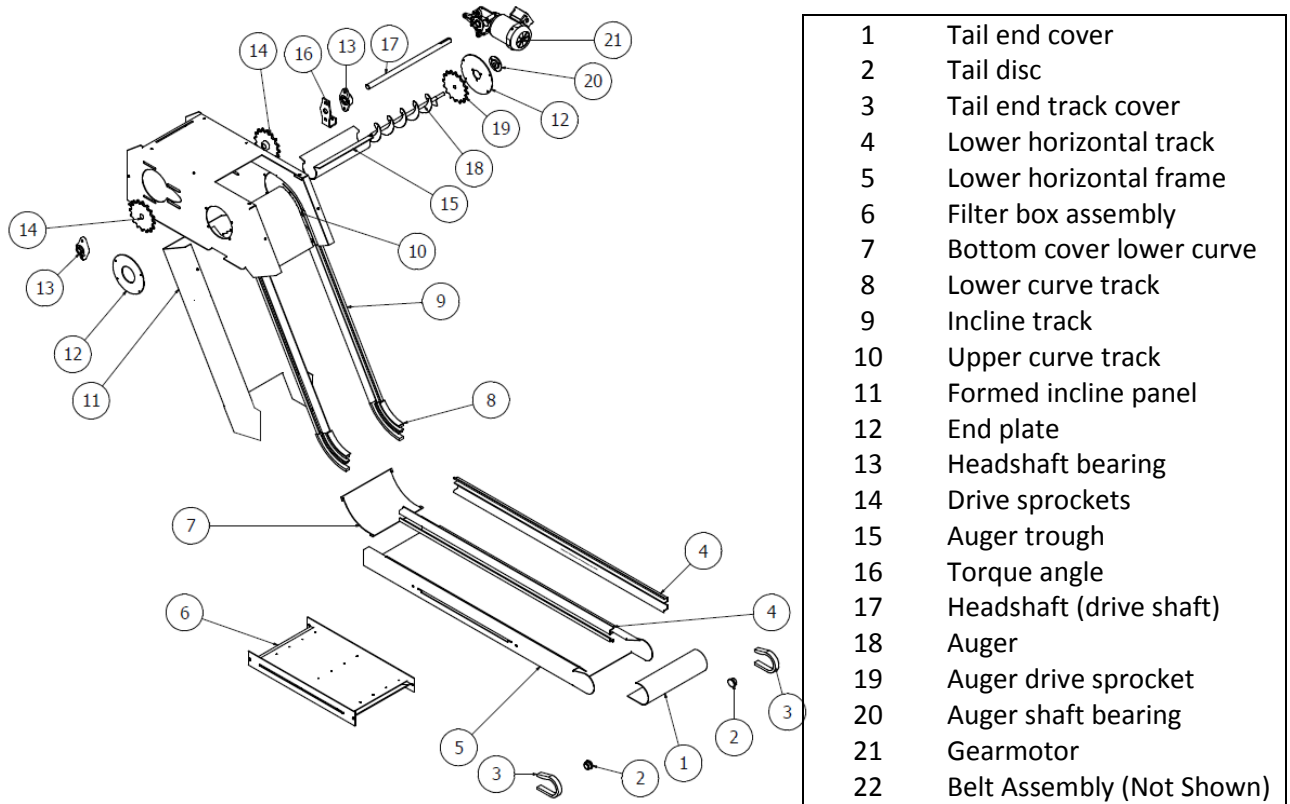

Figure 1a: Conveyor nomenclature.

OPERATION

CleanSweep-RM™ is designed to remove all types of materials, such as steel, cast iron, aluminum, brass, etc. from a stream of coolant. The bulk of the material is handled by the hinged belt conveyor. The separation of the small chips and fines is produced by a self-cleaning perforated screen. The screen is continuously cleaned by internal brushes and wipers.

The small chips and fines are removed by a patented internal inner pan system and discharges from between the belt strands by an auger at the conveyor discharge.

INSTALLATION / START-UP

UNLOADING

Upon receipt of the equipment on site, a thorough inspection should be performed to spot any damage that may have occurred during transit. It is the responsibility of the installer to check and sign for all items contained on the shipment, as well as verify that all items have arrived, and are in good condition.

The packing slip, which accompanies the shipment, will contain a detailed listing, with descriptions, of all of the items on a particular shipment. All items should be checked against this list.

REPORTING DISCREPANCIES OR DAMAGE ITEMS

Any damage, however slight, should be noted on the bill of lading. Any discrepancies between the packing list and received items, or, any pieces damaged, must be reported immediately to Mayfran International. Pictures of damaged equipment while still on the truck are helpful. Notify the Traffic Manager at Mayfran International at: (216) 461-4100, extension 267.

If accepted damaged, and not noted on the bill of lading, the customer is responsible to file a damage claim within 15 days of acceptance of the conveyor with the trucking company.

LIFTING GUIDELINES FOR CONVEYORS

Unloading should be performed in a safe and professional manner to protect both workers and the equipment. Rigging cables, slings, chains, or chokers should be of correct size and in good condition and placed on the equipment in a way that minimizes structural and paint damage. Care must be taken when lifting CONSEP 2000™ conveyor to prevent distortion. Avoid impacts to frames that might cause distortion and misalignment problems during installation. Lifting hooks are normally provided on Mayfran conveyors and tanks. Only use hooks that are designated for lifting. Be sure that slings will not deform conveyor parts. A spreader must be used if it appears that side panels, guards, etc. may be deformed by the sling.

STORAGE OF EQUIPMENT AWAITING INSTALLATION

Any outside storage (exposed to weather) of conveyor equipment must be approved in writing by an authorized Mayfran representative. Conveyor components awaiting installation should be protected from moisture and the elements. Steel belting will oxidize rapidly if exposed to moisture, which will affect the appearance and flexibility of the belt. Painted surfaces can become dull in appearance if exposed to sunlight, even for a short period of time.

INSTALLATION DRAWINGS

General arrangement drawings used for installation have been sent to the equipment purchaser. Should there be any instances where information contained in this manual conflict with the general arrangement drawings specific to this job, the information on the drawings will govern. If there are any questions, please contact the engineer identified on the inspection sticker for clarification.

ELECTRICAL INSTALLATION

All wiring and controls must be installed in accordance with local codes. All work must be performed by licensed electricians. When a conveyor system includes controls, wiring diagrams are normally found in a pocket on the inside of the control box door. Motor wiring diagrams are usually found on the motor nameplate or on the conduit box cover.

SYSTEM INSTALLATION

During operation, the maximum coolant level in the conveyor system is designed to be below the carrying strand of the primary conveyor. This eliminates the possibility of a floating chip problem.

MOTOR ROTATION VERIFICATION

Before starting-up system, the direction of motor rotation must be verified. The operation of the conveyor depends on the proper rotation of the motor. To verify motor rotation, apply power momentarily to the drive by starting the conveyor in the forward direction. Observe the rotation of the driven sprocket (on the head shaft). Repeat in the reverse direction if applicable. If the direction of rotation is not correct, have a qualified electrician reverse the wires. After repairs are completed, recheck the rotation direction.

BELT TAKE-UP ADJUSTMENT

All conveyors are equipped with a belt tensioning device called a take-up. The take-up is usually located at the head end of the conveyor and is used to position the head shaft with respect to the frame of the conveyor. On all Mayfran conveyors, the take-up is designed to move a distance greater than or equal to the pitch length of the belt being used. This insures it will always be possible to properly tension the belt, with the addition or removal of an even number of pitches, even if the length of the conveyor is changed.

Proper chain tension is critical to the reliable operation of any hinged steel belt conveyor. Chains can loosen up after initial run-in on new conveyors or after long periods of time as components begin to wear. One of the sure signs of a loose chain is an observed jerking motion of the belt hinge pan when running. A chain that is too loose may jam and cause the conveyor to become inoperable. A chain that is too tight, may cause excessive wear of chain components and create overloads on the drive system.

CONVEYOR

CHECKING BELT TENSION

The following procedure is used to properly check the tension the belt:

1. Lock out the power to the conveyor.
2. With a hammer, tap hard on the center of the hinge link that is just beyond the head shaft.
3. If the hinge link collapses and stays collapsed, the belt is too loose. See "Tightening the Belt chain" below.
4. If the hinge link collapses and springs back into its original position, the belt chain is properly tensioned.
5. If the hinge link cannot be collapsed, the belt chain is too tight. See "Loosening the Belt chain" below.
6. Turn the power back on to the conveyor.

CAUTION: Whenever the guards are removed or any adjustment is made to the take-up, power must be removed from the conveyor using OSHA approved lock-out / tag-out procedures.

TIGHTENING THE BELT

1. Remove drive chain guard and belt sprocket covers.
2. Loosen the jam nuts and pillow block bearings on the take-up assembly. Also, loosen the jam nuts and mounting bolts on the drive assembly.

NOTE: Be sure to loosen the drive assembly before adjusting the belt, since the drive assembly will move in the same direction.

3. Tighten the belt take-up equally on both sides of the conveyor until belt tension feels correct. Check belt tension, follow procedures explained above.

NOTE: Make sure the head shaft is square to the conveyor frame. This can be checked by measuring the distance from the head shaft to the front face of the conveyor. The dimension should be the same on both sides. If the belt runs to the side, the head shaft is not square.

4. Adjust drive assembly to properly tension the drive chain.
5. Tighten the bearings, drive assembly, and the jam nuts.
6. Allow the conveyor to run for several complete revolutions.
7. Check belt tension, again.
8. The belt must be centered on the head shaft. Clearances between the belt sprocket and the side bars on both sides of the head shaft should be equal. If the belt is not centered, tighten the side where the sprocket is close to the outside side bar (or loosen the other side). Tighten only a couple of turns then restart the conveyor and observe the belt for at least one complete revolution. Repeat as required until centered.

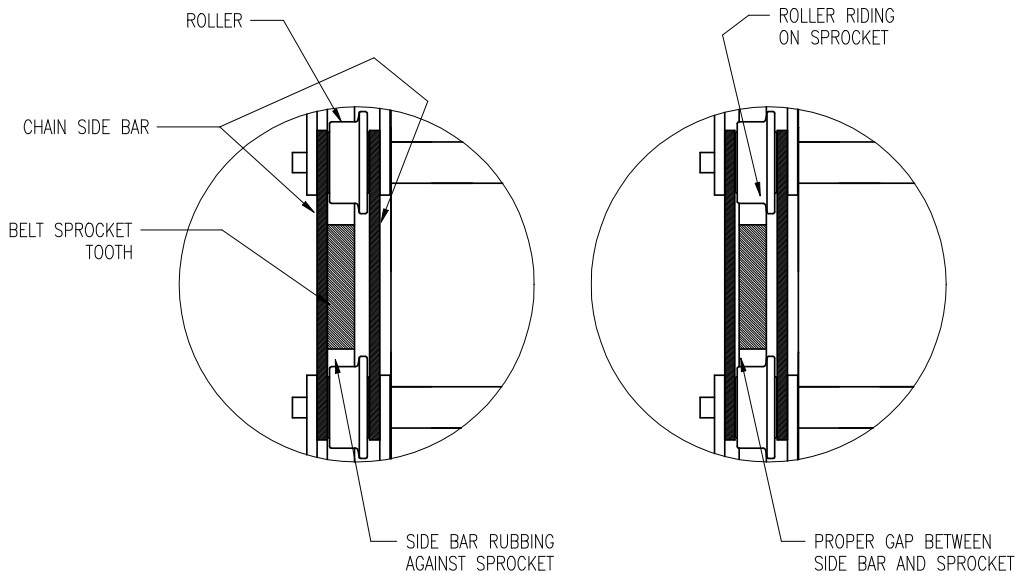

Figure 1d: Top view of head or tail shaft at belt sprocket showing proper clearances between belt side bars and sprocket teeth.

9. Ensure that all guards are properly installed.

NOTE: Use extreme caution while working around an operating conveyor.

LOOSENING THE BELT

1. Remove guards and belt sprocket covers.
2. Loosen the jam nuts and pillow block bearings on the take-up assembly. Also, loosen the jam nuts and mounting bolts on the drive assembly.

NOTE: Be sure to loosen the drive assembly before adjusting the belt, since the drive assembly will move in the same direction.

3. Loosen the belt take-up equally on both sides of the conveyor until belt tension feels correct. Check belt tension, follow procedures explained above.

NOTE: Make sure the head shaft is square to the conveyor frame. This can be checked by measuring the distance from the head shaft to the front face of the conveyor. The dimension should be the same on both sides. If the belt runs to the side, the head shaft is not square.

4. Adjust drive assembly to properly tension the drive chain.
5. Tighten the pillow block bearings, drive assembly, and the jam nuts.
6. Allow the conveyor to run for several complete revolutions.
7. Check belt tension, again.
8. The belt must be centered on the head shaft (See Figure). Clearances between the belt sprocket and the side bars on both sides of the head shaft should be equal. If the belt is not centered, tighten the side where the sprocket is close to the outside side bar (or loosen the other side). Tighten only a couple of turns then restart the conveyor and observe the belt for at least one complete revolution. Repeat as required until centered.
9. Ensure that all guards are properly installed.

REMOVAL OF MAJOR COMPONENTS

BELT REMOVAL

Turn the belt until the belt pin with split pins appears at the open section of the drive-end. Loosen the bolts and remove the chain guards. Loosen the take-up bolts about 15 mm, the belt will now slacken off.

Remove the split pin from the belt pin in the bottom strand. The belt pin can now be pulled from the belt. Remove the chain-connecting link on both sides. The belt is now split, so it can be removed from the frame using the drive motor.

REMOVING THE GEARMOTOR:

Remove the torque bolt. The gear motor can now be pulled from the shaft.

REMOVING DRIVESHAFT:

1. The belt must be separated and removed from the shaft before attempting to remove the shaft.
2. Remove the gearmotor and remove any other interference from around the head shaft.
3. Remove the bolts on each side that hold the pillow block bearings in place.
4. Now, rotate the head shaft and walk it out of the frame along the bottom strand of belt.

ASSEMBLY:

Assembled in reverse order. Please note the direction of belt travel. The side wings should overlap in travel direction (see drawing). Make sure before assembly that all worn or damaged parts are replaced.

IMPORTANT:

Both adjustment bolts must be tightened evenly. Incorrect adjustment may result in excessive wear of chain and/or sprockets.

MAJOR COMPONENT REPLACEMENT

CONVEYOR

DIRECTION OF BELT TRAVEL

Mayfran belting is typically designed for travel in one direction only. Reversing operation is available for special applications. The direction of travel is determined by the side wings and/or the Mayfran logo. When standing at the tail of the conveyor and looking at the discharge end, the Mayfran logo stamped on the belt hinge links should be able to be read as shown in Figure 2. The side wings are designed to have a “shingling” look to them as they move along the conveyor. This is designed to maximize material containment.

Proper belt orientation must be verified at the beginning of belt installation. When installing a belt into the lower tracks visualize the direction of belt travel (toward the tail end) and orient the belt accordingly.

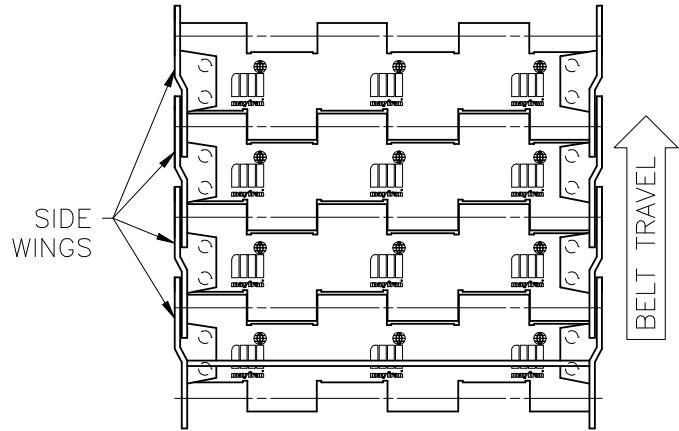

Figure 2: Top view of belt showing proper side wing orientation. (See note)

BELT ASSEMBLY REPLACEMENT

While installing belting into the frame, the belt sections are spliced together as needed. Steel belting is shipped from the factory in lengths of approximately 6 to 10 feet. The belt is usually stacked in a way that provides the proper cleat spacing as consecutive lengths are taken from the top of the skid.

Belting can be assembled either right side up or upside down. When installing the belt into the lower tracks, the belt must be assembled upside down.

All steel belting has a row of chain on each side of the belt. The chain consists of side bars, and roller block assemblies. The outer, or “D” hole side bars are held onto the belt pins with cotter pins, or lock nuts and washers.

All 1 ¼" pitch and 2" pitch belt assemblies are riveted together and in most cases are assembled in one piece.

PROCEDURE FOR ASSEMBLING CONVEYOR BELTING (REFER TO THE FOLLOWING FIGURES)

1. Remove all pins from the skidded belt at splice ends.
2. Lay the first two belt sections out on the floor (or any other work surface) near the point of the conveyor where the belt will be fed in. Align the sections.
 - a. Make sure the belt is oriented properly. Check side wings as shown in previous sections for correct direction of travel.
 - b. The belt is going to be fed into the lower tracks, the belting must be assembled upside down.
 - c. Verify cleat spacing if the belt is equipped with cleats. Check installation drawings for cleat spacing.

3. The first step is to install the belt pin:
 - a. Rotate the roller blocks up and out of the way, on one section of belt. Rotate the side bars out of the way on the other section.
 - b. Bring the two belt sections together and mesh the hinge links.
 - c. Rotate the inner side bar, and roller block down into position on the far side.
 - d. Drive the belt pin in through the hinge link, all the way through until it is flush with the near side edge. Doing this will drive the pin all the way through and past the roller block on the opposite side.

NOTE: Use care to prevent damaging the end of the pin.

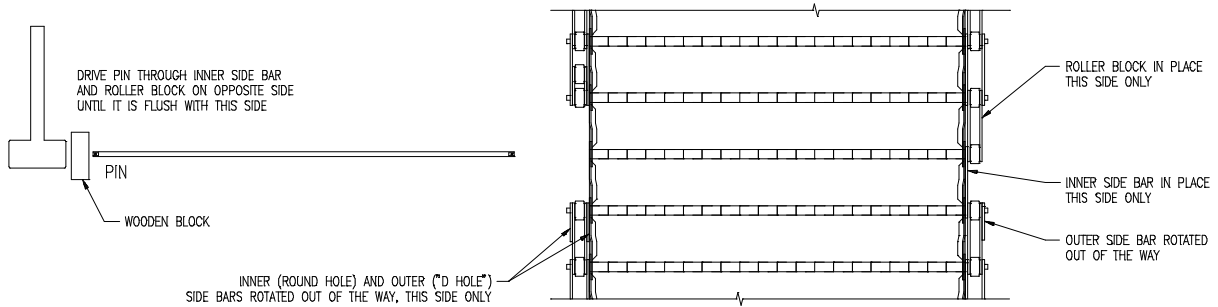

Figure 3: Installation of belt pin.

- e. Next, rotate the inner side bar and roller block down into position on the near side, and drive the pin back until it is flush with the roller block.
 - f. At this time, rotate the pin as necessary to line up the flat on the pin end with the “D” shaped hole in the outer side bar on the far side. A pair of channel lock pliers can be used to do this.

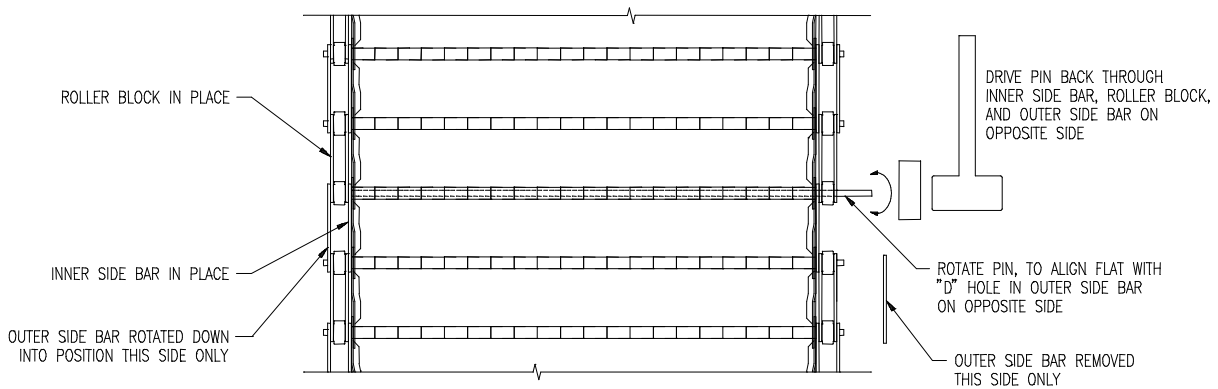

Figure 4: Installation of belt pin back through roller block assembly.

- g. Remove the outer “D” hole side bar on the far side, and rotate the outer side bar and pin down into position on the near side.
- h. Continue driving the pin through the outer side bar until the hole for the cotter pin is visible.
- i. Install a new cotter pin on this end.
- j. Drive the side bar on the far side onto the pin ends.
- k. Install a new cotter pin on both pin ends.

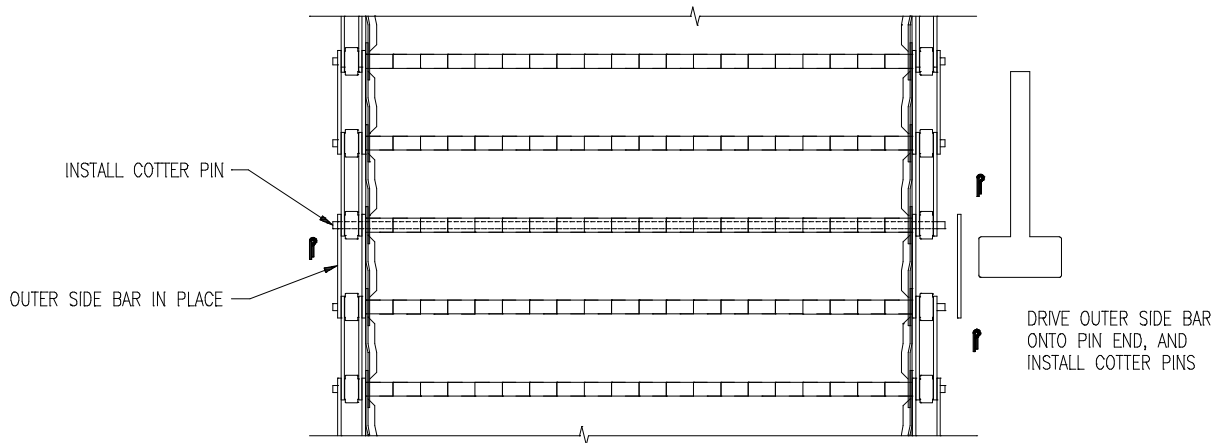

Figure 5: Connecting final side bar to pin.

4. To reassemble the belt into the conveyor, reverse the process of the removal (See section “REMOVAL OF MAJOR COMPONENTS / PRIMARY CONVEYOR / BELT ASSEMBLY REMOVAL”).
5. Before resuming operation of the conveyor system, make sure to check the belt tension.
6. Finally, be sure to check that the adjustment screws are locked in position.



PRIMARY CONVEYOR BELT ASSEMBLY

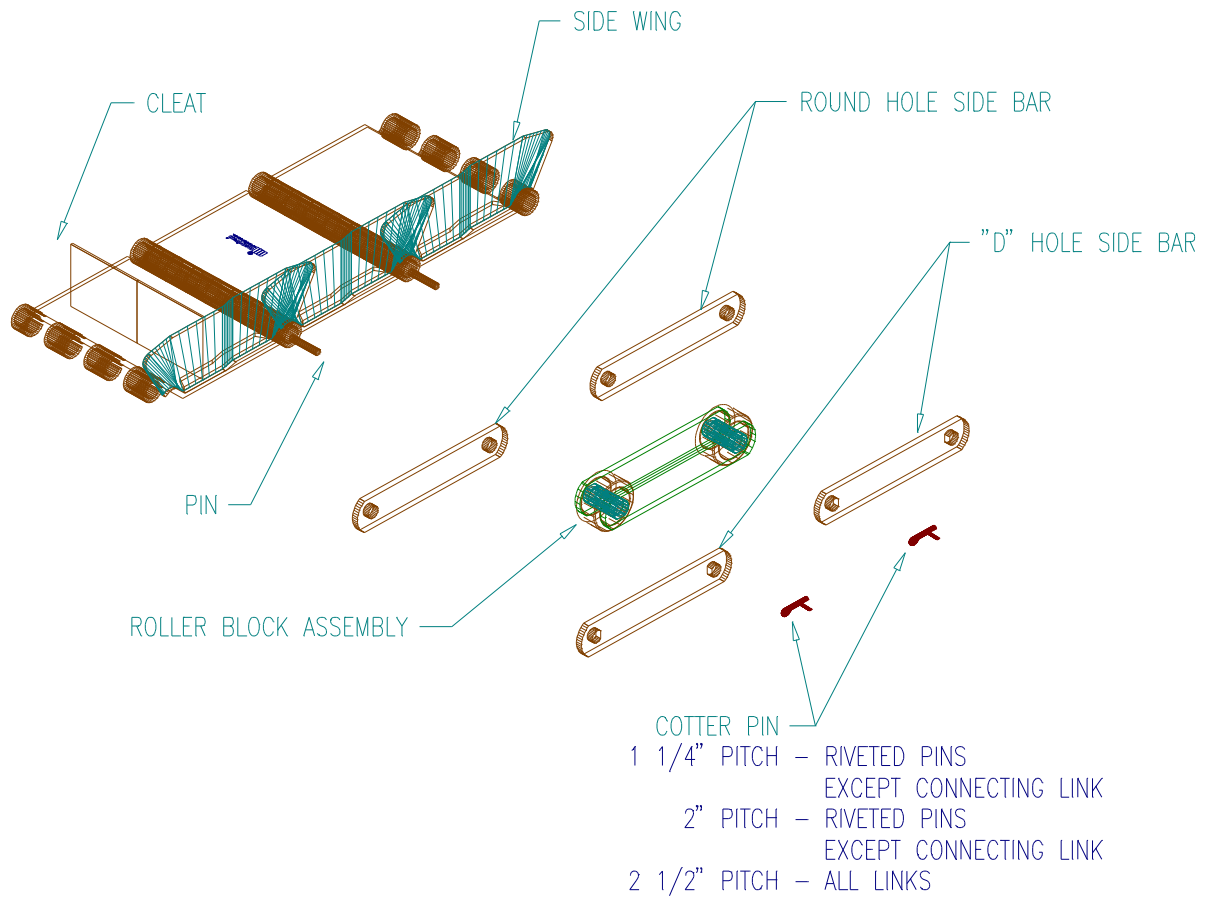

Figure 6: Exploded view of primary conveyor belting.

HEAD SHAFT ASSEMBLY REPLACEMENT

1. To reassemble, follow in reverse order the removal of the head shaft assembly (See the section "REMOVAL OF MAJOR COMPONENTS / CONVEYOR / HEAD SHAFT ASSEMBLY REMOVAL).
2. Before resuming operation of the conveyor system, make sure to check the belt tension (See the section "CONVEYOR / CHECKING BELT TENSION).
3. Be sure to replace all the guarding on the conveyor system.

MAINTENANCE

PREVENTIVE MAINTENANCE

By far the most important preventive maintenance activity is to keep the conveyor clean. Removing excess material will prolong the life of the belt, bearings, and reducer, and ensure that limit switches and other electronic sensors will perform as they were designed. The frequency of machine cleaning depends on the type and amount of material being conveyed.

The other vital maintenance item is to insure that all components of the conveyor are well lubricated. This includes the belt chain, roller chain, bearings, take-up screw and reducer. For information on the motor, reducer, and bearings, refers to the appropriate manufacturers' publication for the type of lubricant to be used.

The only other preventive maintenance that needs to be performed is a periodic inspection and testing of the conveyor components. The following table lists recommended maintenance items and minimum intervals. It is recommended that the end users maintenance manager produce their own preventive maintenance schedule based on these minimums. Accurate records of any maintenance performed must be maintained. These are general intervals; consult the technical manuals of your specific components for exact intervals.

ITEM	DESCRIPTION	INTERVAL
1	Check condition of all labels and safety decals. Replace if missing, damaged, or difficult to read.	Daily
2	Clean conveyor and remove any debris	Daily
3	Check belt brush and wiper assemblies to make sure they are engaged on the bottom pan. Adjust if necessary	Monthly
4	Check steel belt tension. Adjust if necessary - lubricate where required	Monthly
5	Check the screen on the filter box assembly. Clean when necessary	Monthly
6	Check roller chain adjustment/lubricate	Every 6 months
7	Lubricate take-up assembly	Every 6 months

TROUBLESHOOTING

OVERVIEW

Mayfran conveyors are designed to be the most reliable in the industry. However, problems may occur on occasion. Problems are normally discovered in one of two ways:

- ◆ A fault is received on the main control panel. Troubleshooting for these faults is briefly discussed in the charts on the following pages. For a complete guide to troubleshooting of electrical controls, consult your Mayfran Electrical Controls Manual.
- ◆ The second indication that problems are discovered is simply by the operator noticing that there is something different about the way the conveyor is operating; usually there is some sort of unusual noise. The only way to correct this problem is to examine the conveyor and determine the source. The common sources of noise are different for new conveyors and for conveyors that have been operating properly for some time.

Common causes for both cases are listed in the tables below:

NEW CONVEYORS
Side wings contacting the frame
Rollers binding in frames or curves
Uneven tracks
Poor alignment at frame joints or belt sprockets
Stiff hinge links (belt not articulating through curves or around shafts)
Sprocket rubbing against chain guard
Cleats striking frames

OPERATED CONVEYORS
Bent side wings
Material on tracks
Poor alignment
Worn rollers
Material between the belt and frames
Broken welds
Failed bearings
Failed motor or gear reducer
Improperly adjusted and/or worn roller chain or v-belts
Loose take-up
Binding in the belt

It is imperative that any unusual noises are identified, diagnosed, and corrected immediately to prevent serious damage from occurring.

JAM CLEARING SEQUENCE

1. Clear the top surface of the belt and jog reverse the conveyor to see if the jam clears itself.
2. Check for foreign objects jammed between the belt and the frame.

NOTE: *Check the belt tension in as many places as possible. One section of the belt will normally be tight. The rest of the belt will normally be loose (slightly movable). The jam will be at the end of the tight section.*

3. Check the space between the belt and the bottom cover for any foreign matter. Clear any jam in this area by removing the material with a long bar. Do not attempt to remove it by applying force to turn the head shaft.
4. Check the sprockets at the tail and head of the conveyor for foreign matter.
5. Finally, check the tail and head shaft bearings

The following tables briefly describe faults that may appear on the conveyor control panel. Most conveyors have some type of motion sensor, and others may be equipped with a clutch limit switch used with a Mayfran Safety Clutch. All conveyors are equipped with an overload sensing device that will shut down the conveyor in the event of a motor overload. Note: This is an abbreviated listing only. Please consult your Mayfran Electrical Controls manual for a complete list of diagnosis.

CONVEYOR MOTION FAULTS

SYMPTOM	PROBABLE CAUSE	POSSIBLE SOLUTION
Conveyor not running: Motor not running	Breaker open	Reset Breaker
	Open circuit to motor	Correct wiring
	Bad motor	Check motor
Conveyor not running: Motor running	Clutch engaging	Clear blockage, restart conveyor
	Loose belt	Adjust take-up to tension belt
	Broken/slipping v-belts	Replace/tension v-belts
	Broken drive chain	Repair/replace drive chain

OVERLOAD FAULTS

An overload fault is caused by tripping the overload device that supplies power to the conveyor. After the overload device is reset, and any obvious cause corrected, the conveyor should be run in local mode, and the amperage draw on the motor checked. Also, check the current setting on the overload device.

SYMPTOM	PROBABLE CAUSE	POSSIBLE SOLUTION
Overload Fault	Conveyor loaded beyond rated capacity	Reduce loading
	Conveyor Jammed	Clear jam
	External drag or load	Check skirt boards, flaps, wipers, etc. properly installed
	Component failure	Check/clean/replace bearings, gearbox, and belt rollers which may be binding

COOLANT OVERFLOW ISSUES

The conveyor is sized to properly handle the pre-determined coolant flow from the machine.

SYMPTOM	PROBABLE CAUSE	POSSIBLE SOLUTION
Coolant overflowing the belt	Pumps were added and/or valves were opened to increase coolant flow	Adjust valves to factory setting
	Coolant is foaming and overflowing the conveyor	Add a defoamer and contact the coolant supplier
	The screen on the filter assembly is plugged	Adjust the wiper and brush assemblies to engage the bottom pan.
		Remove the filter assembly and clean



**P.O. BOX 43038
6650 BETA DRIVE
CLEVELAND, OHIO 44143**

**PHONE: (440) 461-4100
FAX: (440) 461-5565**