

OPERATION AND MAINTENANCE MANUAL AUTO BELT CLEANER

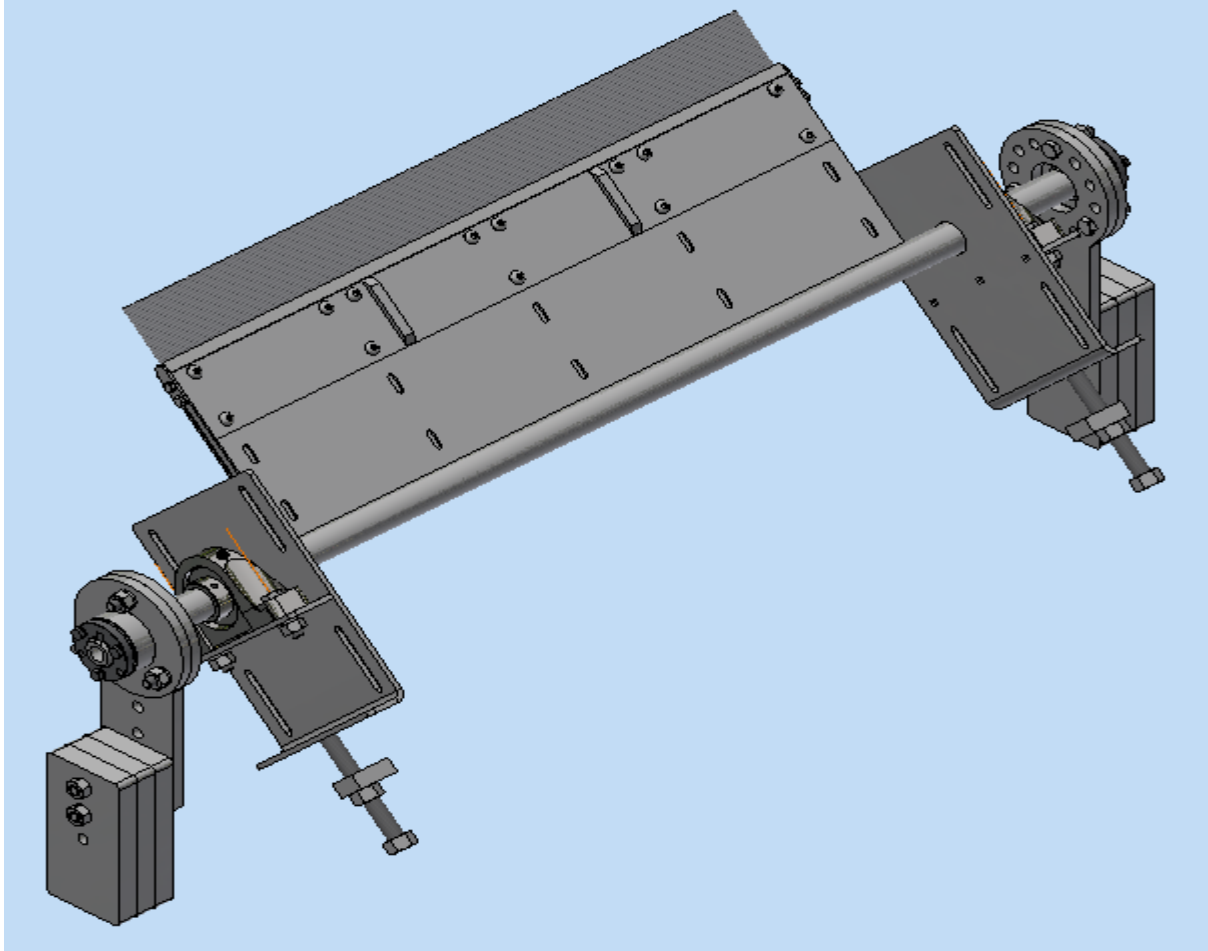

Mayfran International, Incorporated

**P.O. BOX 43038
6650 BETA DRIVE
CLEVELAND, OHIO 44143**

**PHONE: (440) 461-4100
FAX: (440) 461-5565**

TABLE OF CONTENTS

Table of contents	ii
Warranty statement	3
Safety information	4
Parts list	5
Part order ordering instructions	6
Operation & Adjustment... ..	7-10
Maintenance.....	11

WARRANTY STATEMENT

(a) Mayfran International Inc. ("Mayfran") warrants to the original purchaser that during the first 2000 hours of operation, but in no event more than one year from the date of shipment (the "Warranty Period"), the equipment sold will conform to the design, construction, and performance, if any, specifications set forth in Mayfran's proposal, quotation, or sales order acknowledgment for the equipment and will be free from significant defects in material and workmanship (the "Product Warranty"). The Product Warranty does not apply if: (i) the equipment has been subject to misuse, negligence, improper maintenance (including improper lubrication), or improper handling, (ii) the defect or non-conformity arises out of the failure to follow Mayfran's oral or written instructions regarding the equipment, including instructions as to storage, installation, commissioning, use or maintenance; (iii) the equipment has been reconstructed, repaired or altered by parties other than Mayfran or its authorized representatives; or (iv) the equipment has been used with any third-party products, hardware or product that has not been previously approved in writing by Mayfran. As the sole and exclusive remedy (and Mayfran's entire liability) for a breach of the Product Warranty, during the Warranty Period Mayfran will, at Mayfran's cost and option, repair any nonconformity on site or replace any nonconforming part. Notwithstanding the foregoing, purchaser is responsible for labor charges to install replacement parts.

(b) EXCEPT FOR THE PRODUCT WARRANTY SET FORTH ABOVE, (1) NEITHER MAYFRAN NOR ANY PERSON ON MAYFRAN'S BEHALF HAS MADE OR MAKES ANY EXPRESS OR IMPLIED REPRESENTATION OR WARRANTY WHATSOEVER, EITHER ORAL OR WRITTEN, INCLUDING ANY WARRANTIES OF MERCHANTABILITY, FITNESS FOR A PARTICULAR PURPOSE, OR PERFORMANCE OF EQUIPMENT (INCLUDING THROUGH-PUT PERFORMANCE) TO STANDARDS SPECIFIC TO THE PURCHASER'S NEEDS, WHETHER ARISING BY LAW, COURSE OF DEALING, COURSE OF PERFORMANCE, USAGE OF TRADE OR OTHERWISE, ALL OF WHICH ARE EXPRESSLY DISCLAIMED, AND (2) THE PURCHASER ACKNOWLEDGES THAT IT HAS NOT RELIED UPON ANY REPRESENTATION OR WARRANTY MADE BY SELLER, OR ANY OTHER PERSON ON SELLER'S BEHALF, EXCEPT FOR THE PRODUCT WARRANTY.

(c) Mayfran does not warrant any equipment, parts, or components where Mayfran is not the manufacturer. For equipment, parts and components not manufactured by Mayfran, only the warranty, if any, provided by the manufacturer is available, a copy of which will be provided on request.

(d) Mayfran is not liable for consequential, indirect, incidental, special, exemplary, punitive or enhanced damages, for lost profits or revenues, or for diminution in value, arising out of or relating to any breach of the Product Warranty or otherwise, regardless of (i) whether such damages were foreseeable, (ii) whether or not the purchaser was advised of the possibility of such damages or (iii) the legal or equitable theory (contract, tort or otherwise) upon which the claim is based, and notwithstanding the failure of any agreed or other remedy of its essential purpose.

Rev 17-0314

SAFETY INFORMATION

THE SAFETY INFORMATION CONTAINED HEREIN MUST BE COMMUNICATED BY THE CUSTOMER, OWNER, OR END USER TO ALL PERSONNEL WHO WILL ACTUALLY OPERATE, MAINTAIN, REPAIR, OR ADJUST THIS EQUIPMENT, OR WHO ARE ASSIGNED TO WORK IN THE VICINITY OF THIS EQUIPMENT.

ADJUSTMENT, MAINTENANCE AND CLEANING SHOULD BE CONDUCTED ONLY BY PERSONNEL TRAINED BY THE OWNER OR END USER IN THE OPERATION OF ALL ASSOCIATED EQUIPMENT. PERSONNEL SHOULD BE TRAINED IN OSHA COMPLIANT LOCK-OUT / TAG-OUT AND ELECTRICAL SAFETY PROCEDURES. RECORDS OF TRAINING SHOULD BE MAINTAINED BY THE OWNER OR END USER. RECORDS OF TRAINING FOR THE SAFE OPERATION OF THIS EQUIPMENT MUST ALSO BE MAINTAINED. NEVER SHOULD ADJUSTMENT, MAINTENANCE, OR CLEANING BE PERFORMED WITHOUT FOLLOWING PROPER SAFETY PROCEDURES.

DO NOT operate any equipment or machinery without reading and understanding this manual completely.

DO NOT operate any equipment or machinery unless fully trained and qualified by the owner or end user.

DO NOT operate any equipment or machinery (or any portion) unless all personnel are clear of any rotating or moving parts (or parts that may potentially move or rotate).

DO NOT operate any equipment or machinery unless all guards and/or emergency stops are in place and functioning as designed.

DO NOT perform any maintenance, repairs, or adjustments on this equipment without first locking out all electrical controls.

DO NOT clean the equipment or the areas adjacent to or below the machinery without first locking out all electrical controls.

DO NOT remove any covers or guards without disconnecting the power.

DO NOT remove or cover any warning labels.

DO NOT climb on the components of the equipment.

MAYFRAN INTERNATIONAL, INCORPORATED WILL NOT BE RESPONSIBLE FOR ANY WORK PERFORMED, OR ALTERATIONS MADE TO ANY OF ITS PRODUCTS UNLESS PRIOR APPROVAL HAS BEEN GRANTED IN WRITING BY AN AUTHORIZED MAYFRAN REPRESENTATIVE. ANY OTHER WORK WILL VOID ANY AND ALL WARRANTIES AND LIABILITIES. ALL WARRANTIES AND LIABILITIES SHALL ALSO BE VOID IF PARTS MANUFACTURED BY MAYFRAN INTERNATIONAL ARE REPLACED WITH PARTS OBTAINED FROM A SOURCE OTHER THAN MAYFRAN INTERNATIONAL.

PARTS LIST FOR AUTO BELT CLEANER

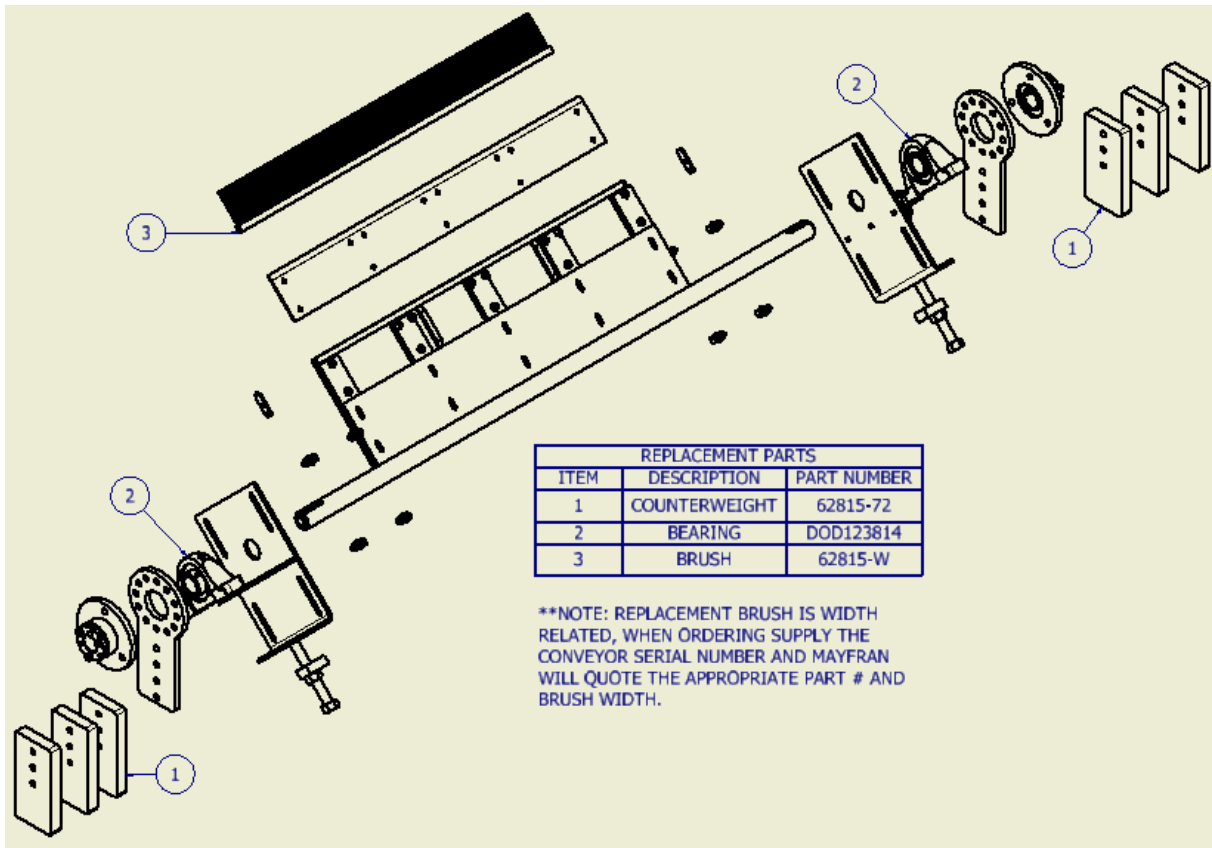

OPERATION

AUTO BELT CLEANER is designed to automatically clean the belt from any scrap that is left after scrap discharge.

PARTS ORDERING INSTRUCTIONS

When ordering parts, please specify the following information:

1. **Part Number:** Specify the Mayfran part number as given in this manual.
2. **Quantity:** Specify how many are required.
3. **Name of Part:** Use the proper description or title, given in the owner's manual.
4. **Shipping Instructions:** Specify complete shipping instructions: Such as parcel post, truck, 2nd day air freight, or overnight air freight, along with the required ship date. When no instructions are given, shipping method will be best way, depending on nature of part and urgency of repair. Customer will pay freight costs.
5. **Return Address:** When ordering parts, always include your complete address with phone number. Keep in mind that parts cannot be delivered to a Post Office box.
6. **Returned Parts:** New parts returned to the factory will be subject to a restocking charge incurred unless parts were sent by mistake from the factory. No part may be returned to the factory without prior written authorization from Mayfran (RGT #).
8. **Shortage:** If any parts are missing, other than parts marked back ordered, call the factory immediately.



**P.O. BOX 43038
6650 BETA DRIVE
CLEVELAND, OHIO 44143**

**PHONE: (440) 461-4100
FAX: (440) 461-5565**

MAINTAINING AND OPERATING THE AUTO BELT CLEANER

AUTO BELT CLEANER ADJUSTMENT (BRUSH)

As the Auto Belt Cleaner wears, it will be necessary to periodically adjust the brush to maintain contact with the belt and to ensure proper cleaning.

- 1) Loosen the (8) 3/8-16 nuts (4 on each side) that hold the Take-ups in place. (See Below)

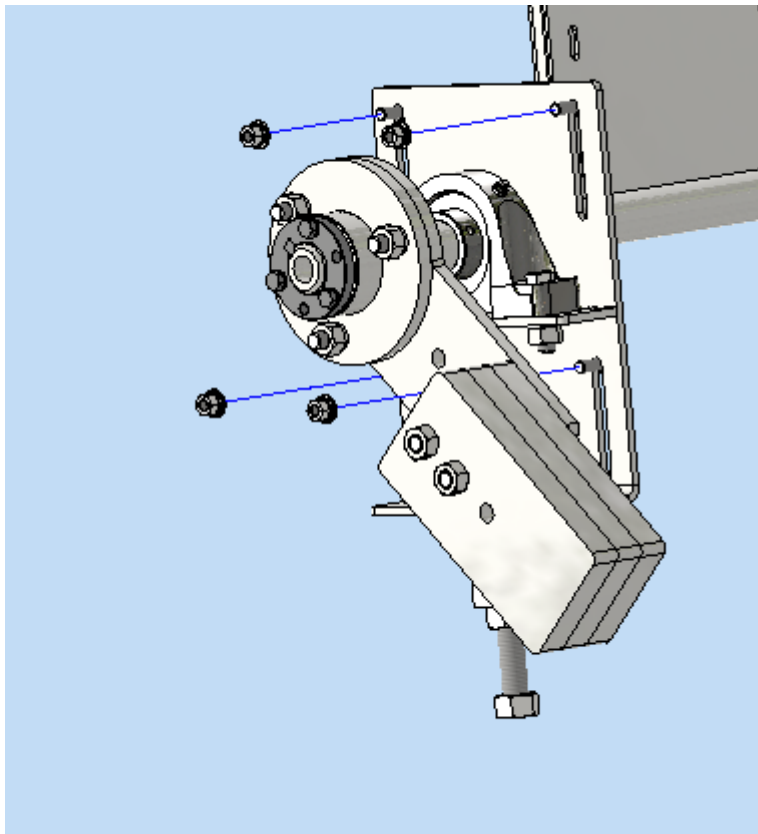

- 2) After the (8) nuts are loosened, loosen the Take-up nut, and adjust the take-up. (See below)

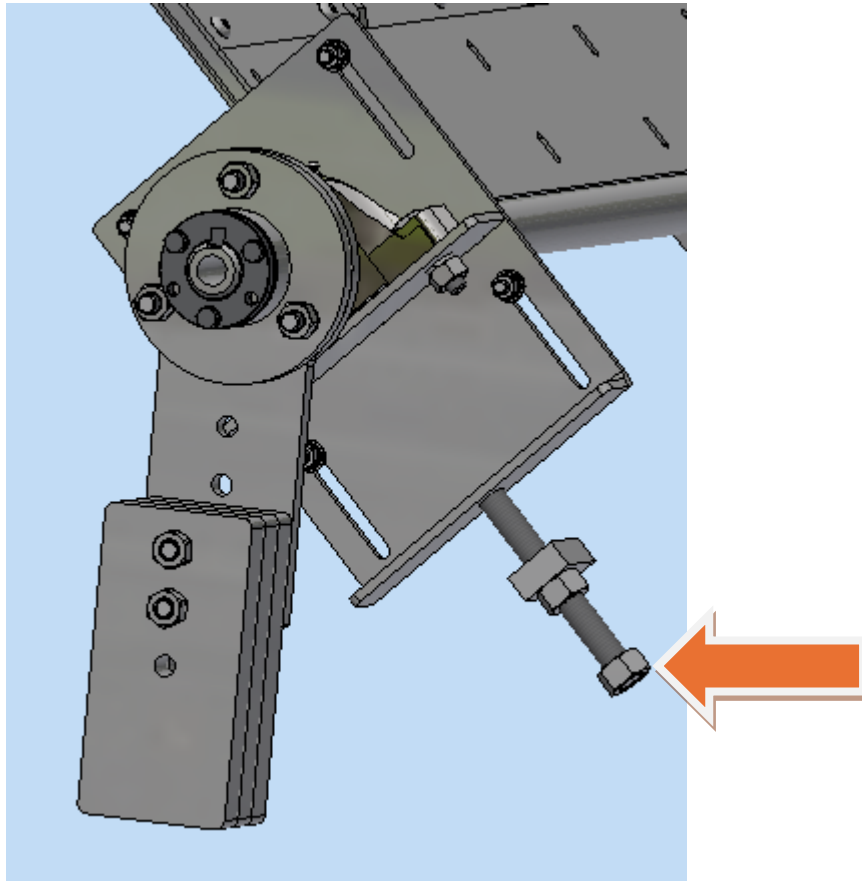

- 3) Make sure to always adjust each side the same. (If the left side is adjusted 6 turns, the right side will need to be adjusted the same.)
- 4) Adjust the take-ups until the brush is engaging the belt and is cleaning properly.
- 5) Tighten the take-up nut and the (8) nuts on the take-up and periodically check for brush engagement with the belt.
- 6) As the take-up is adjusted forward, the brush will become more worn and will eventually need to be replaced. See below picture for when to replace the brush.

When the Auto Belt Cleaner is initially installed the brush will be new and no adjustments will be needed. As the Brush wears and the take-up is adjusted the brush will become worn and eventually the brush will need to be replaced. As this occurs, the nut and bolt will move from “New Brush” towards “Brush at 50%” and eventually reach “Brush Replacement needed”. (See Below) When this occurs, a new brush will be needed. See next page for how to replace the brush.

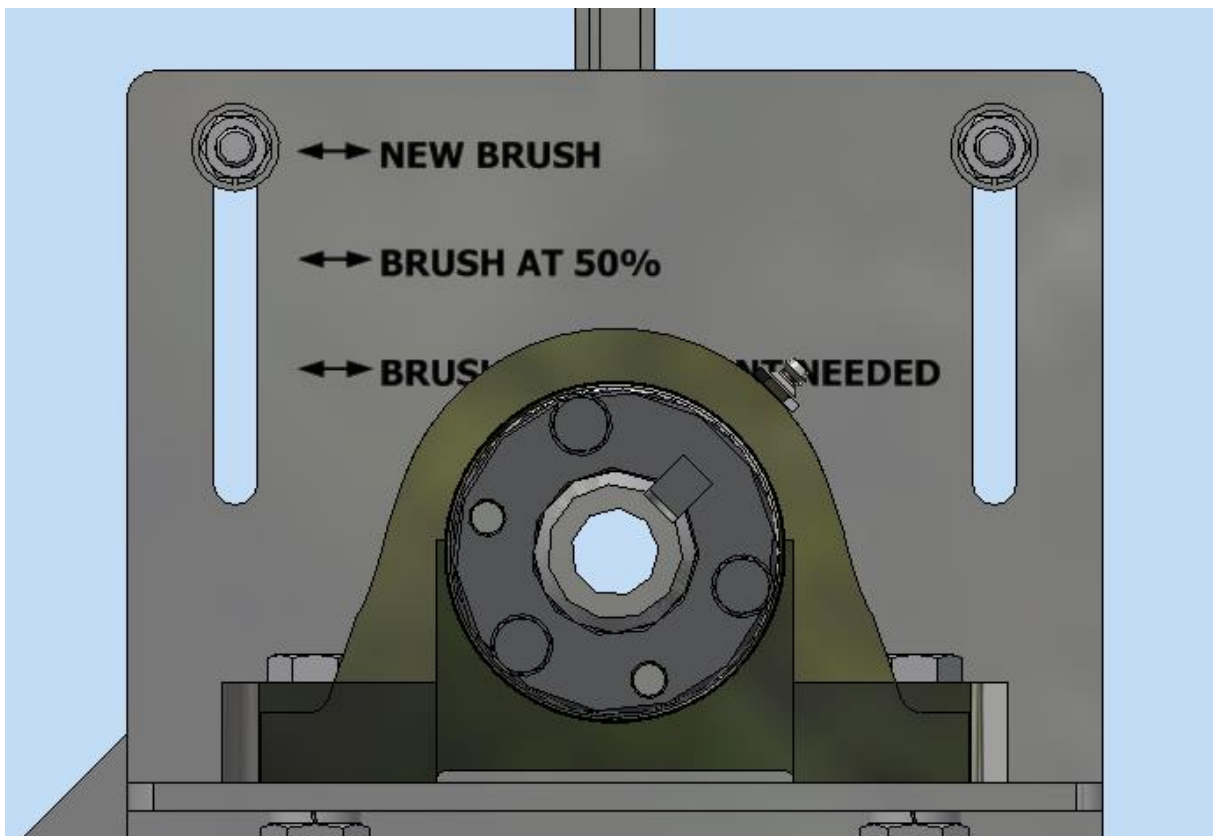

***** Warning*****

Never go below, “Brush Replacement Needed.”

Brush must be replaced at this time!!!

AUTO BELT CLEANER BRUSH REPLACEMENT

As the Auto Belt Cleaner wears, it will be necessary to periodically replace.

- 1) Loosen (13) 3/8-16 Button Head hex screws, remove plate. (see below)

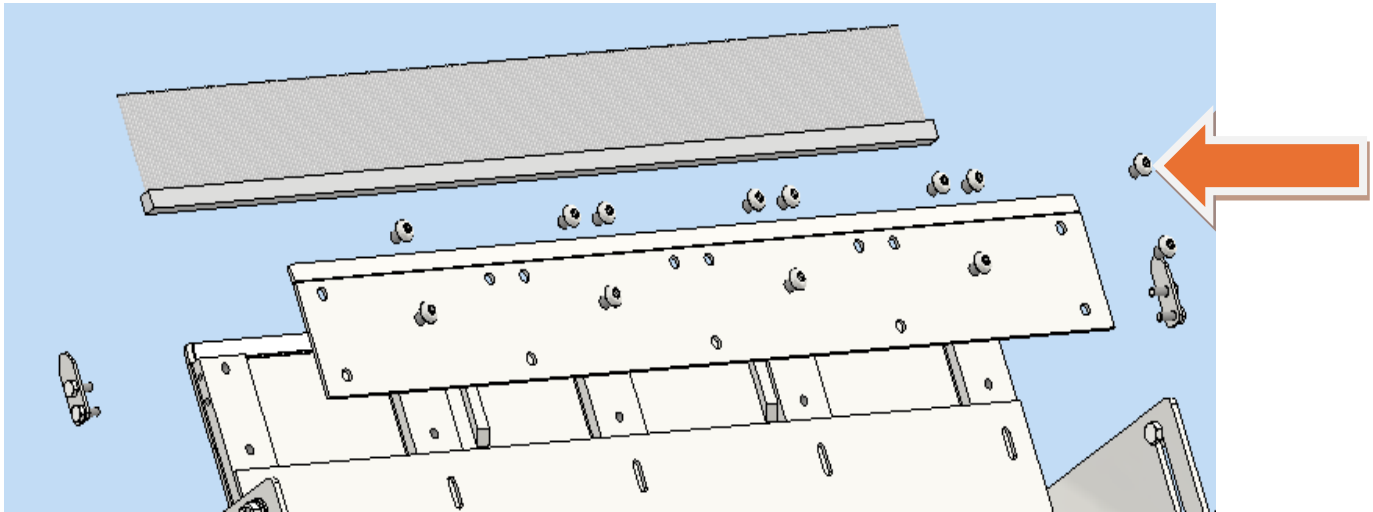

- 2) Remove old worn brush and replace with new brush.
- 3) Replace plate and screws, tighten and Loc-tite if needed.
- 4) Access to the brush can be had through the bottom of the dribble chute if possible or through the access window on the dribble chute. (See below)

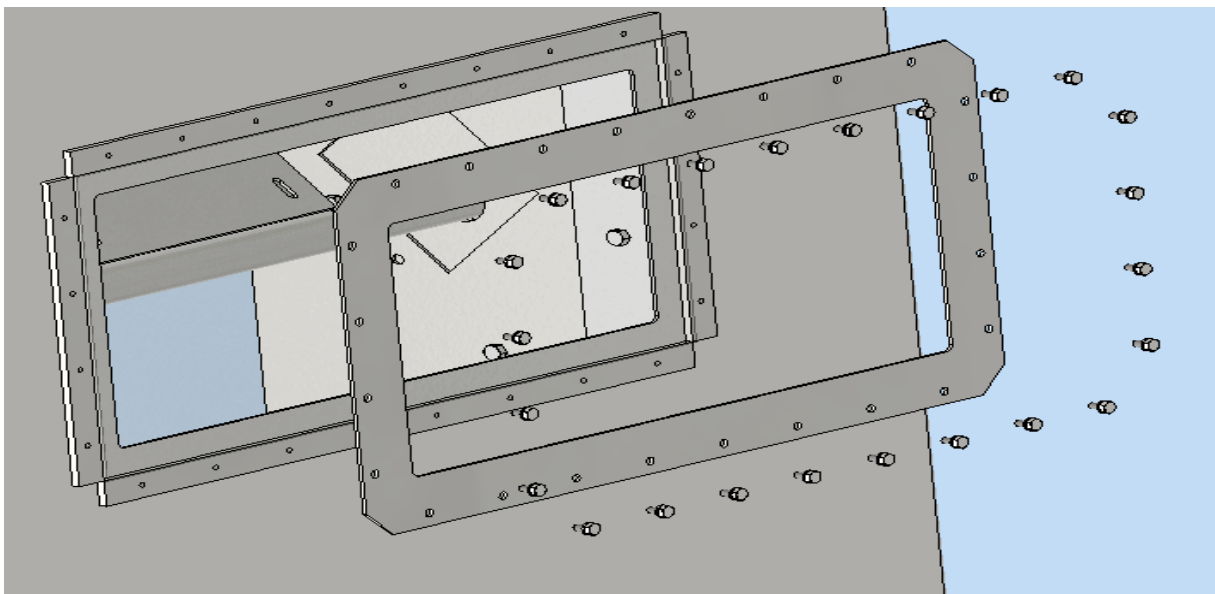

MAINTENANCE

PREVENTIVE MAINTENANCE

By far the most important preventive maintenance activity is to make sure the brush is engaged on the belt and scrap build-up is not occurring inside of the dribble chute. Removing excess scrap build up will prolong the life of the components. The frequency of cleaning depends on the type and amount of material being conveyed.

The other preventive maintenance that needs to be performed is a periodic inspection of the equipment. The following table lists recommended maintenance items and minimum intervals. It is recommended that the end users maintenance manager produce their own preventive maintenance schedule based on these minimums. Accurate records of any maintenance performed must be maintained.

ITEM	DESCRIPTION	INTERVAL
1	Check condition of all labels and safety decals. Replace if missing, damaged, or difficult to read.	Daily
2	Clean exterior and remove any debris	Daily
3	Check brush to ensure proper contact with belt. Adjust if necessary	Daily
4	Check all fasteners. Tighten if necessary.	Monthly
5	Inspect inside dribble chute for excess scrap. Clean if necessary	Monthly

TROUBLE SHOOTING GUIDE

SYMPTON	PROBABLE CAUSES	POSSIBLE SOLUTIONS
Brush is not engaging the belt and/or the belt is not clean.	Brush is worn and/or needs replaced	"See" Auto Belt Cleaner brush adjustment section. (Pgs. 7-9)
		"See" how to replace brush. (Page 10)



**P.O. BOX 43038
6650 BETA DRIVE
CLEVELAND, OHIO 44143**

**PHONE: (440) 461-4100
FAX: (440) 461-5565**