

AT-CLEANER SIDE STREAM PACKAGE AND AT MOBILE SEPARATOR

Whether you need an integrated AT-Cleaner for one machine or a portable AT-Cleaner to service multiple machines, we have you covered. Mayfran's AT-Cleaner line is designed to maximize your shop's efficiency and maintain the **highest standards of cleanliness and performance** without the need for disposable filter media. Each system is engineered to deliver robust, filter-free performance, tackling fine particulate effectively and keeping your cleaning operations seamless and cost-effective.

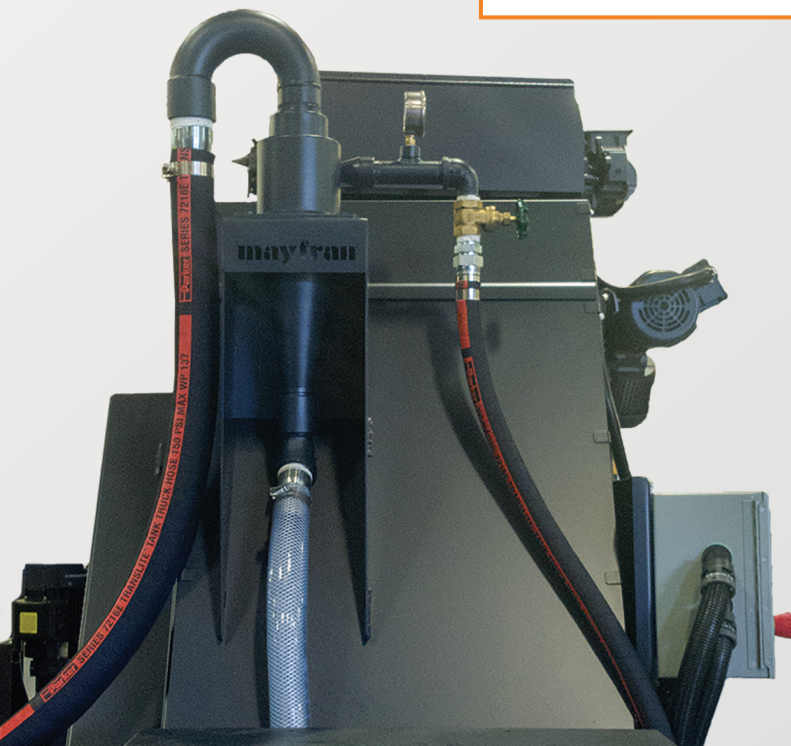

SETTING THE STANDARD FOR MORE THAN 90 YEARS



Mayfran's original AT-Cleaner removes a high percentage of sludge-forming super-fines produced in cast-iron machining. The AT-Cleaner is rated at 10-micron nominal when used as a secondary filter after a separator conveyor.

It uses cyclonic separation technology to clean coolant and can be used as a side stream package or stand-alone unit to reduce PPM or to clean coolant under high pressure. Its industry-leading technology removes fines and super-fines (sludge) from the coolant system.

Note: The AT-Cleaner can only be used with water-soluble coolants.

*Manufactured under license from Bunri Industries.

THE ART OF **MOTION** IN ACTION

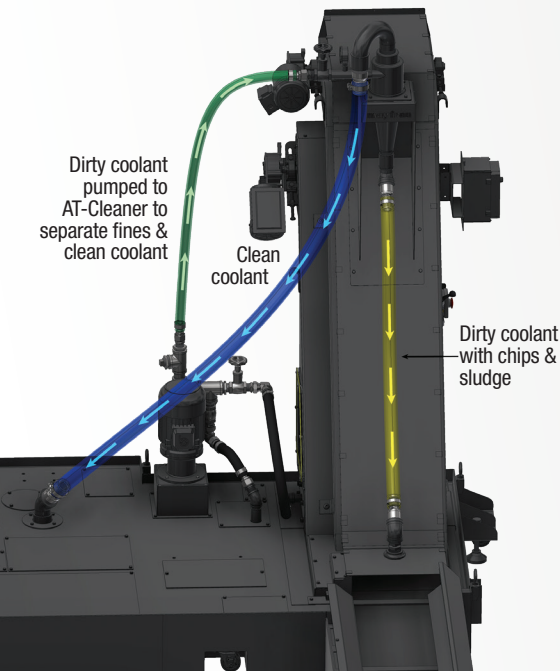

AT-Cleaner Side Stream Package

A Mayfran coolant cleaning and high-pressure coolant system integrated into the chip conveyor and coolant tank can help reduce floor space and piping requirements. The AT-Cleaner Side Stream Package can be retrofitted to any existing chip conveyor.

How It Works

- The feed pump is normally located near where coolant exits the conveyor.
- The pump sends coolant with sludge particles to the AT-Cleaner.
- The AT-Cleaner removes a majority of the sludge particles to 10-micron nominal that are pumped to it.
- The dirty coolant discharges onto the conveyor incline outside of the coolant level.
- The clean coolant is discharged back into the tank near the system pump(s).

AT Mobile Separator

This portable AT-Cleaner Offers Additional Convenience

- The AT Mobile Separator offers the same cyclonic cleaning down to 10-micron nominal as the side stream package but with the added advantage of being able to move between machines.
- The AT Mobile Separator utilizes a heavy-duty marine pump to carry dirty coolant and particulate to an external sludge bin for easy cleanup and removal.
- By reducing maintenance downtime and the need for multiple units, the AT Mobile Separator offers a cost-effective solution for facilities, delivering long-term savings.

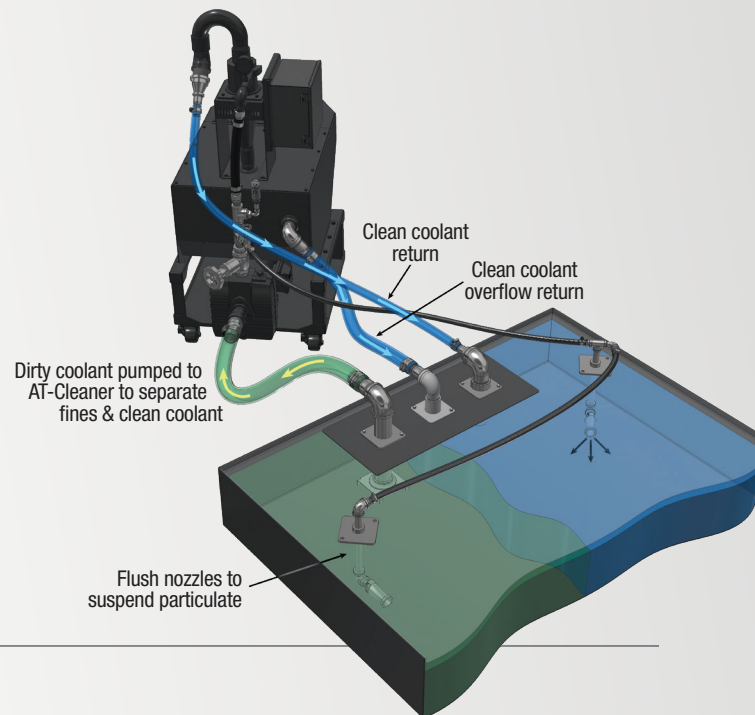

Find Out More Today

Discover all the advantages Mayfran's AT-Cleaner line can offer your facility by visiting www.mayfran.com, or **contact your local Mayfran representative.**

*Manufactured under license from Bunri Industries.

QUALITY, BUILT IN.

Innovation in Motion
TSUBAKI

mayfran
INTERNATIONAL